

TOP VIEW

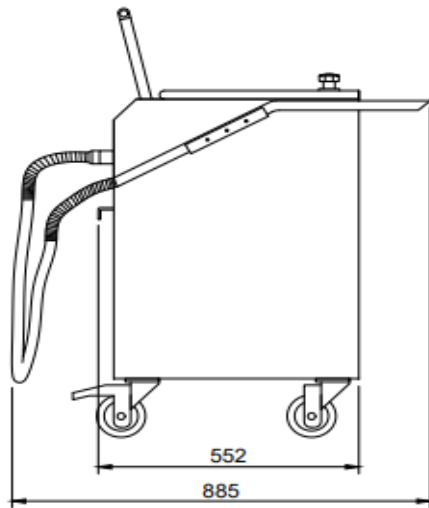

SIDE VIEW
NTS

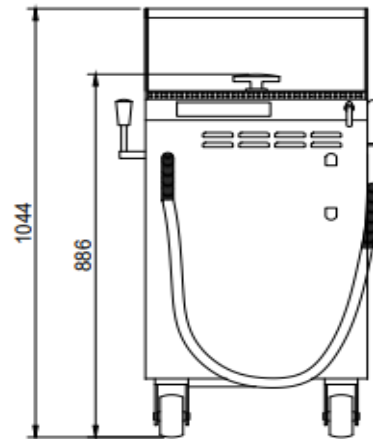

FRONT VIEW

FEATURES INCLUDE:

Normal usage	Ideal for catering industry and bakeries or high frying volume
Filtration power	up to 30 kg/min
Filtration efficiency	up to 5µm
Pumping Capacity	35kg/min
Tank Volume	.075 cubic m/62kg
Particle uptake	10.7 kg
Weight	55.8kg
Temperature	Max. 200 degree Celcius
Material	Stainless steel 1.4301

The **VITO XM** cleans the oil, stores it in its .075 cubic meter (62kg) tank and provides an easy and hygienic transport in the kitchen. Because of its innovative vacuum-filtration technology, particles remain in the filter in a dry condition. Like every VITO oil filter system the XM provides a microfiltration up to 5 µm. The unique design makes sure the XM can handle temperatures up to 200°C and provides highest safety at work, because of avoiding direct contact with the hot oil. After filtration the oil can easily be pumped back into the fryer automatically

Benefits:

1. Increase the lifetime of your oil
2. Improves taste and Quality
3. Saves time and labor