

Save up to 50% on your oil costs with...



With the **VITO® Oil Filter System**, you can almost double the life of your frying oil and improve the quality of your fried product while saving time and money. A unique solution providing the combined benefits of reduced costs, better quality frying, less frequent oil changes and higher quality product to your customers. Simply place **VITO®** in the fryer unit and filtration is completed automatically. No need to drain your fryers and no need to pay for outsourcing expensive filtration services. Choose the unit that suits your operation and start saving up to 50% on your frying oil costs. The optional **VITO® FOM330 Oil Tester** can monitor oil quality and provide data that ensures consistent quality and proper oil replacement schedules to save even more.

Choose the correct model for your fryer capacity



VITO® 30
up to 12 Litres

VITO® 50
up to 20 Litres

VITO® 80
over 20 Litres

VITO FOM330
OIL TESTER

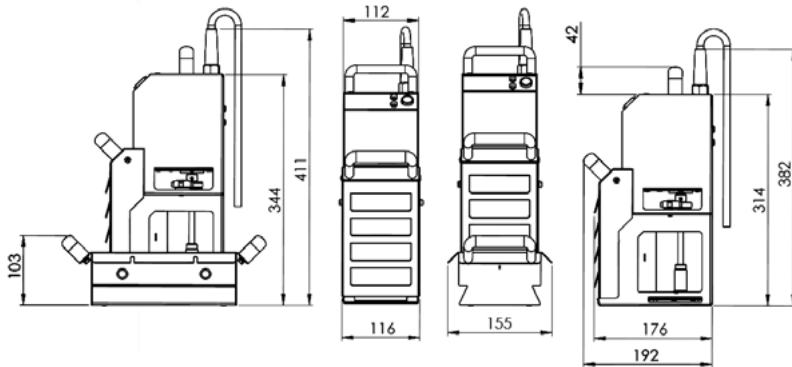

VITO® 30

Filtration power	Particle Uptake	Power	Work Cycle	Suction Depth	Dimensions	Weight
<35L/Min	0.8L	300W	4.5 mins	20cm	W122xH411xL175mm	6.3Kg

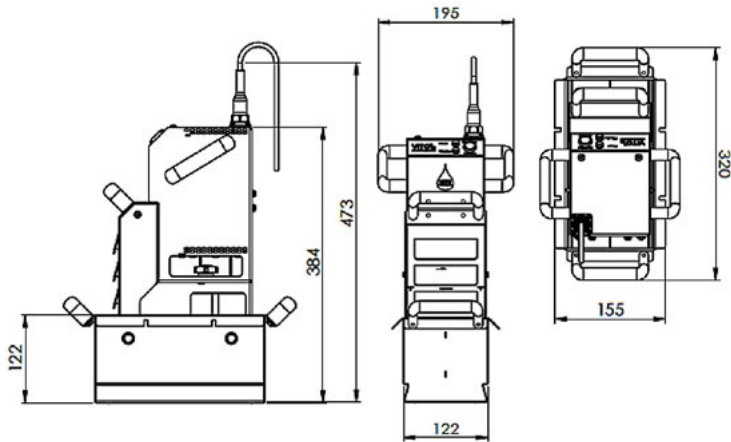

VITO® 50

Filtration power	Particle Uptake	Power	Work Cycle	Suction Depth	Dimensions	Weight
<50L/Min	1.2L	300W	4.5 mins	30cm	W195xH370xL210mm	7.7Kg

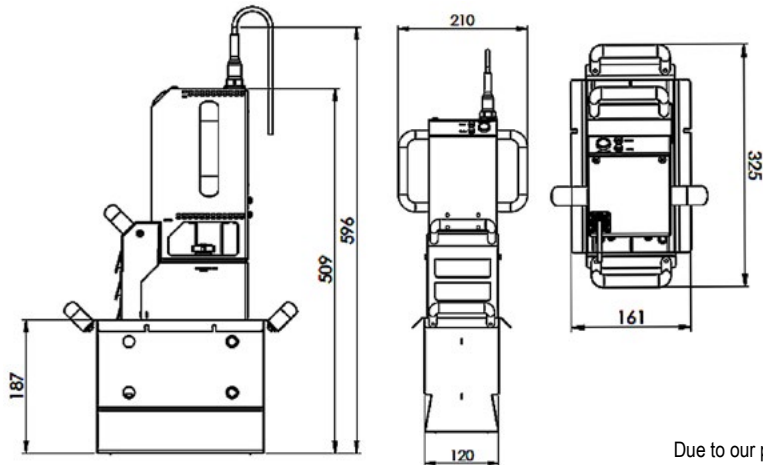

VITO® 80

Filtration power	Particle Uptake	Power	Work Cycle	Suction Depth	Dimensions	Weight
<95L/Min	3.5L	500W	4.5 mins	45cm	W210xH460xL205mm	9.2Kg

Due to our policy of continual improvement, descriptions and technical information may change without notice.